

IN-LINE BITUMEN EMULSION PLANT

Build into a 20 ft. container

Production capacity 10-12 tons/hour
Semi automatic production control

The ENH Engineering A/S bitumen emulsion plant is designed to meet with the high demands for modern emulsion technology. The in-line system of this plant offers the possibility to produce all known bitumen emulsion types.

The in-line system provides great flexibility in the production phase. The different flows for bitumen water and chemicals are controlled individually and can be changed during production without any influence on each other. A great advantage of the in-line system is that there is no need to premix any chemicals or water solutions, all is added continuously during the production which means that the production can continue practically as long as required without any stop.

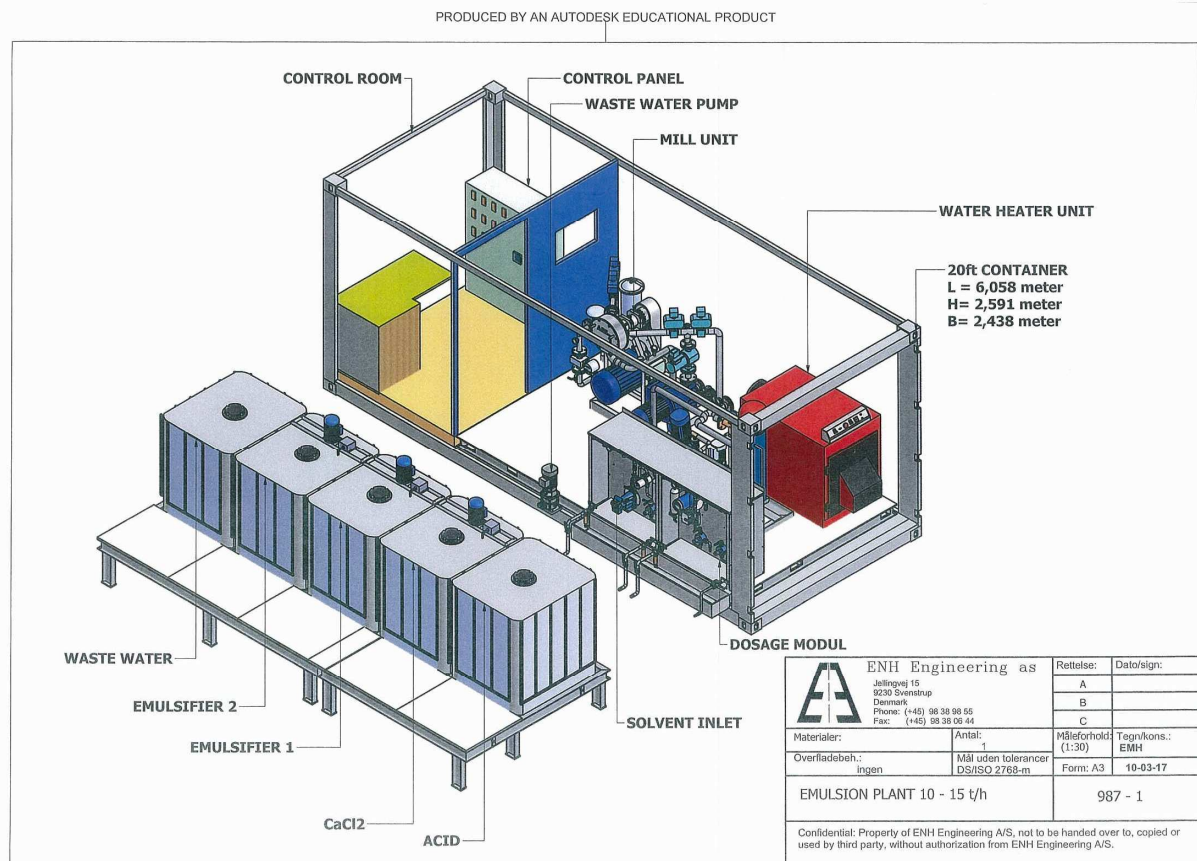

Technical description

- Mill unit
- Bitumen system
- Solvent system
- Water system
- Chemical Unit
- Chemical tank battery
- Emulsion cooling system for heating production water
- Process control system (PCS)

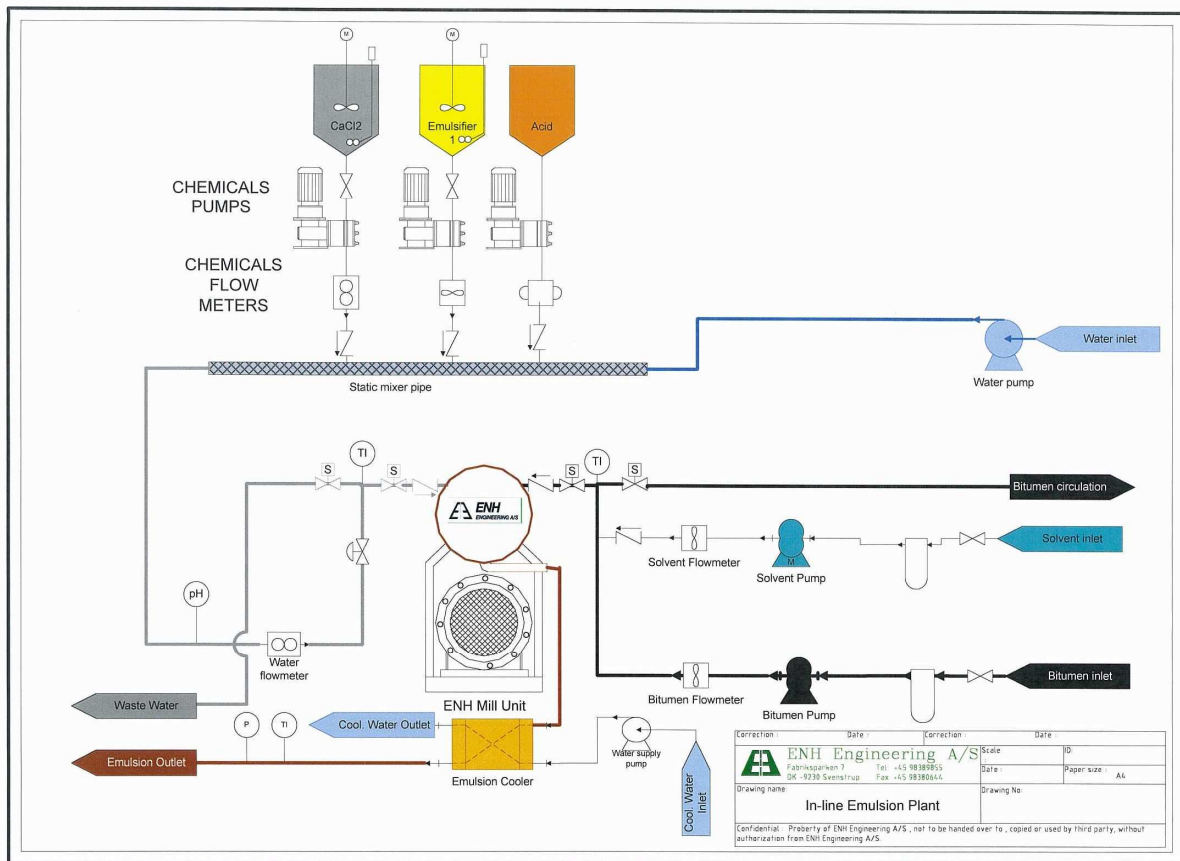

For further information please do not hesitate to contact us.

ENH Engineering A/S
 Jellingvej 15
 DK-9230 Svenstrup
 Denmark

Tel: +45-98389855
 Fax: +45-98380644
 E-mail: enh@enh.dk